

# COLLISION REPAIR INFORMATION

## FOR THE TOYOTA DEALER

TITLE: BODY SEAM AND JOINT SEALER APPLICATION

PAGE 1 of 6

SECTION: EXTERIOR BULLETIN #44

MODELS: ALL

DATE: MAY 1991



During the repair procedures of restoring the vehicle to pre-accident condition, making the seam and joint sealer appear as it did during the assembly line process is made more difficult because of the different types of materials and equipment used.

This bulletin addresses different methods to achieve very nearly the same look as a new vehicle.

### MATERIALS AND TOOLS USED:



Body Sealer, White,  
Cartridge Type

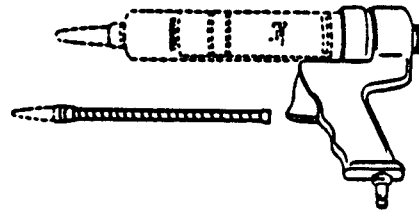

Air Gun Set for Sealer

Reference For Cutting of Sealer Nozzle Ends For Different Shapes:

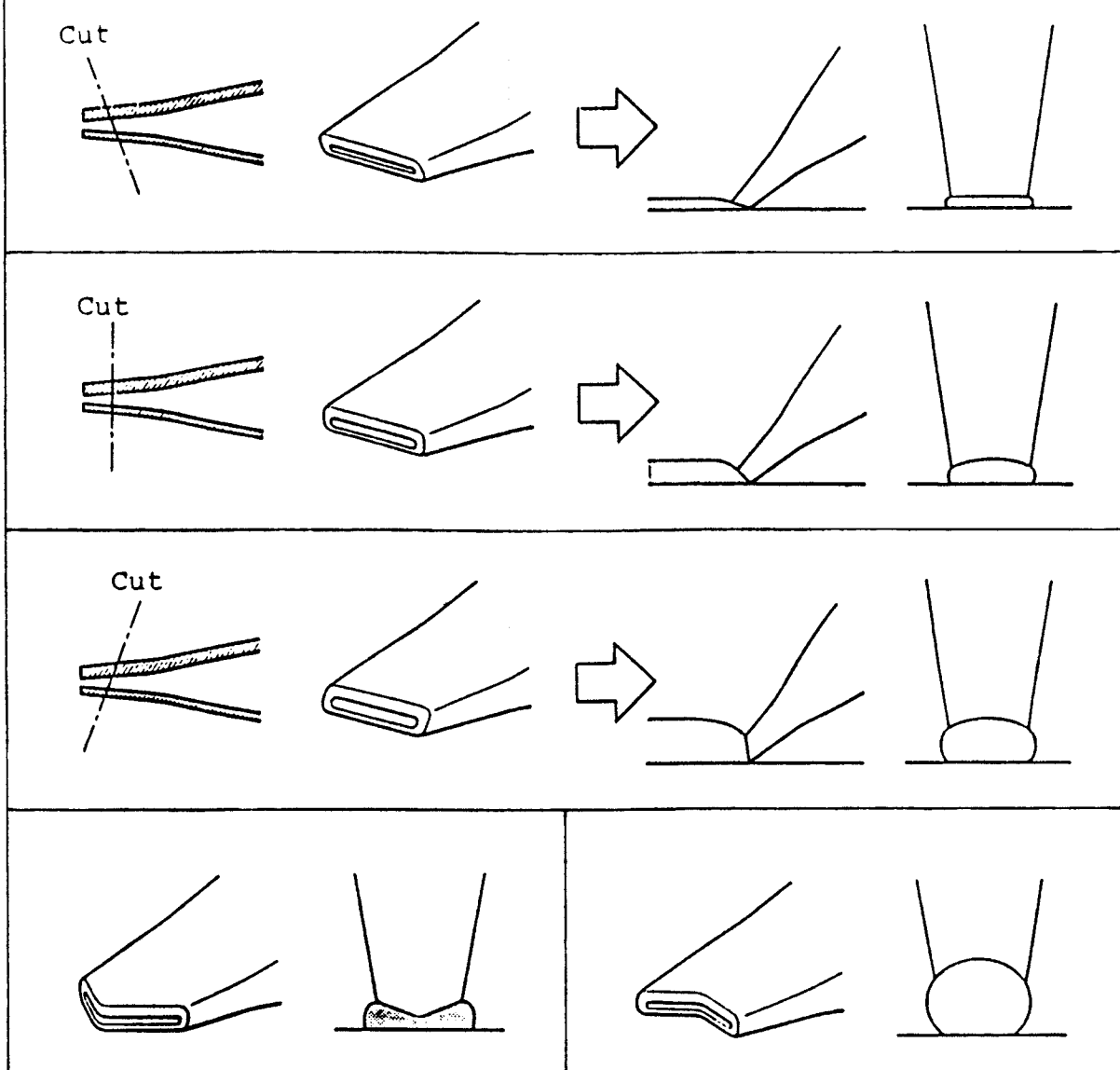

Cartridge Angle and Sealer Application Bead Shape Using Nozzle Cut # 1:

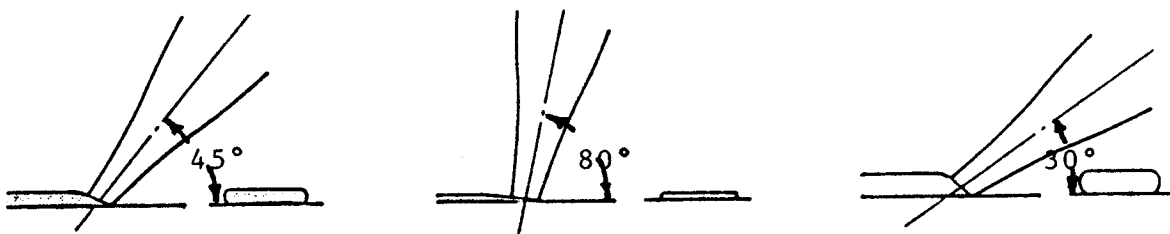

1. Applying Sealer to Hemmed Joints

“Hemmed Joints” are joints with the edge of the panel bent over the edge of another such as the door skin or skin of the hood panel. Prepare the nozzle of the cartridge by cutting 5–6 mm off the end with an appropriate cutter. Heat the end by using a heat gun. Using a pair of pliers, flatten the end of the nozzle so the sealer will be applied in a flat smooth manner.

**CAUTION:** Excessive heat (100 degrees Centigrade or 290 degrees Fahrenheit) will melt the plastic nozzle.

To shape the end of the nozzle, use a flat blade screw driver in the heated end. This will give a uniform flat application of sealer.

**IMPORTANT:** The place where the cut is made determines the width of the sealer bead.

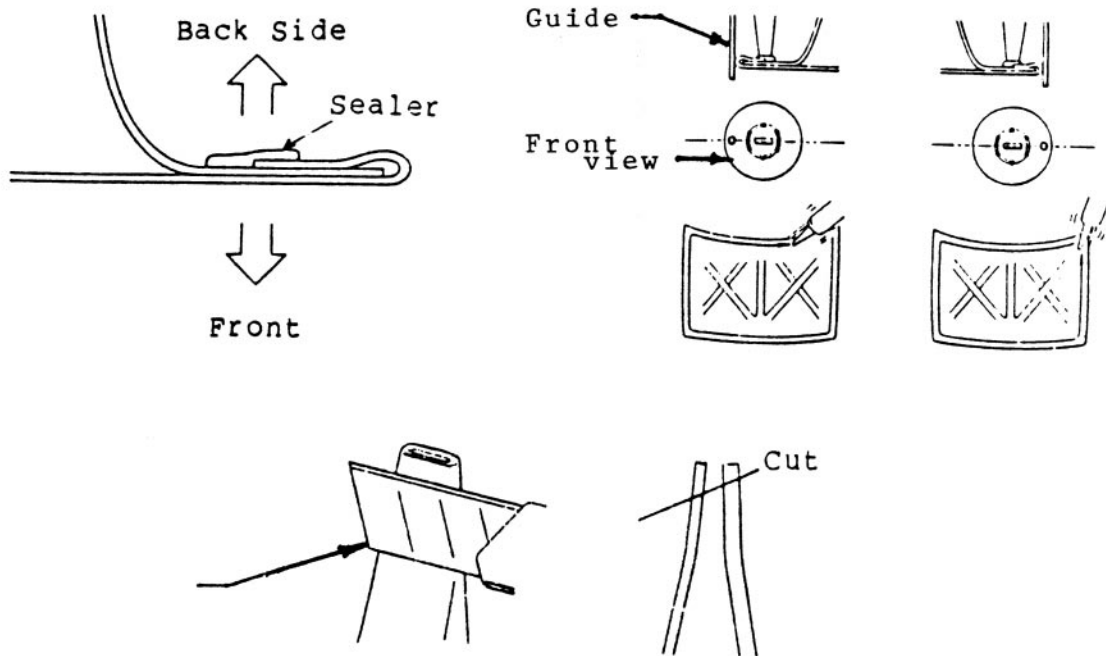

2. Preparing a Nozzle Guide

In order to evenly apply the sealer to the edge of the panel it may be necessary to make a guide. This guide may be made from a simple washer and welding rod. See illustration below:

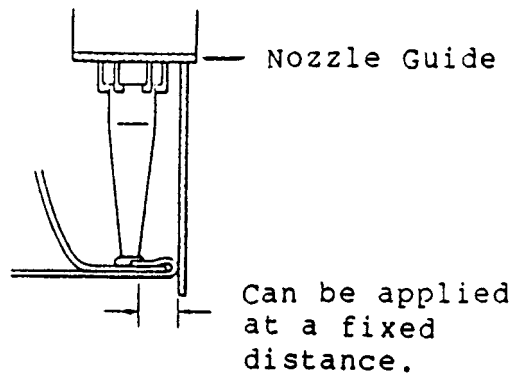
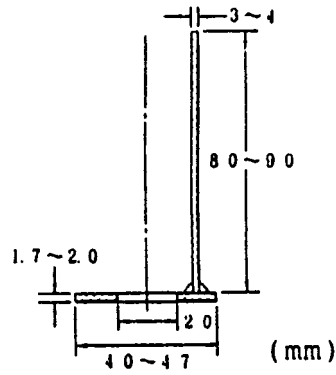
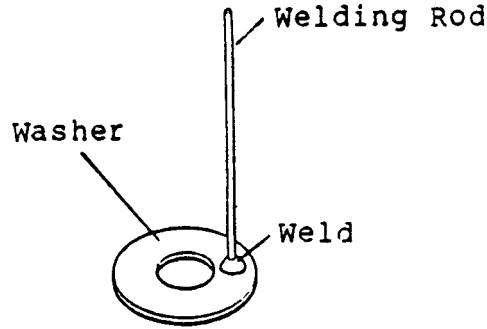

3. Application Procedure

- A. Degrease the area where sealer will be applied. Be certain all the wax and grease remover has been eliminated from the surface before applying the sealer.
- B. Use the nozzle guide to apply an even bead of sealer to edge of the panel. If the edge of the guide does not allow the sealer to be applied in the correct position, bead the guide rod as necessary.
- C. Apply a small amount of sealer to a test panel to check for the correct amount and alignment of sealer being applied.
- D. Apply the necessary amount of sealer to adequately seal the panel from rust and corrosive agents.

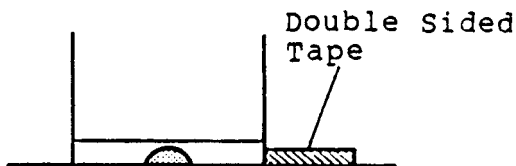
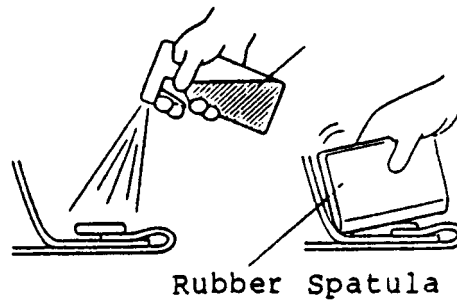

4. Applying Sealer to Rear Body Panels

The use of a shaping spatula may be of help in making the finished application of sealer appear as it did on the original joint. Materials that can be used for this spatula are: (1) hard rubber sanding block, (2) a piece of hard flat plastic. After the initial cutting of the groove has been made, it will be necessary to sand the groove smooth with fine grit sandpaper. This can be done by folding the sandpaper into a U-shape. See Illustration A below.

Place the U-shape groove of the shaping spatula against the panel where the sealer will be applied. Use thick double sided tape along the side of the tool as a guide.

Apply sealer to the panel joint. Use the appropriate round bead of sealer diameter for the joint. Use slightly more than necessary as the excess will be removed by the shaping spatula.

Remove the guide tape and any excess sealer with a wax and grease remover and a shop towel.

**CAUTION:** Use all safety equipment necessary for working with chemicals; i.e., gloves, eye protection, respiratory protection.

